

Description

The Prefill Exhaust Valve (PV) is a hydraulic-pilot operated check valve with seat type construction. It allows free flow from port A to port B. Flow from port B to port A can be enabled by applying pilot pressure to it's port X.

The decompression feature enables the valve to open in two stages progressively, allowing smooth and rapid exhaust of the compressed oil. Opening and closing time of the valve can be influenced by providing Throttle-Check Valves in the X port line.

Flanged port A of the valve housing can be rotated around vertical axis through 360° to facilitate access to flange fixing bolts and flange orientation

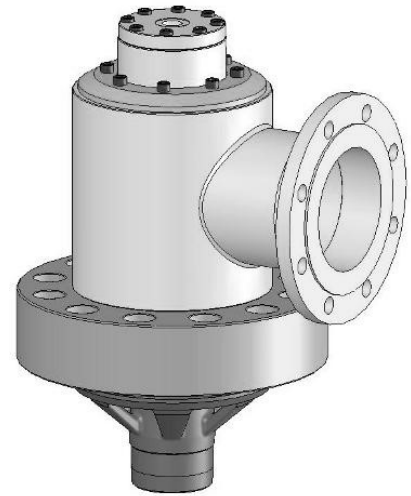

Features

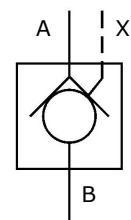
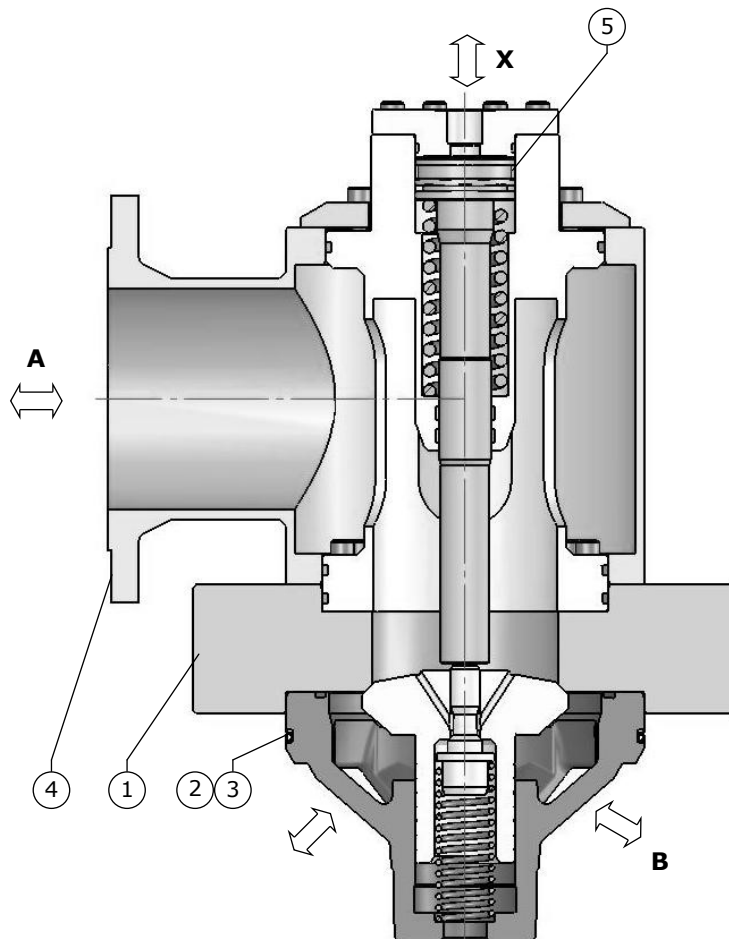

Hydraulic Symbol

1. Integrated Seat provides high rigidity, high fatigue resistance and less deflection of the flange.

2. Encapsulated O-ring allows easy of assembly and prevents o-ring damage during assembly.

3. Simplified Cavity machining

4. Larger suction flange to reduce pressure drop in the suction line and consequently increase flow handling capability

5. Improved Pilot cylinder sealing to minimize pilot leakage and reduce frictional loss during operation.

Installation Dimensions: Mounting Style B—Reservoir (In-tank) Mount

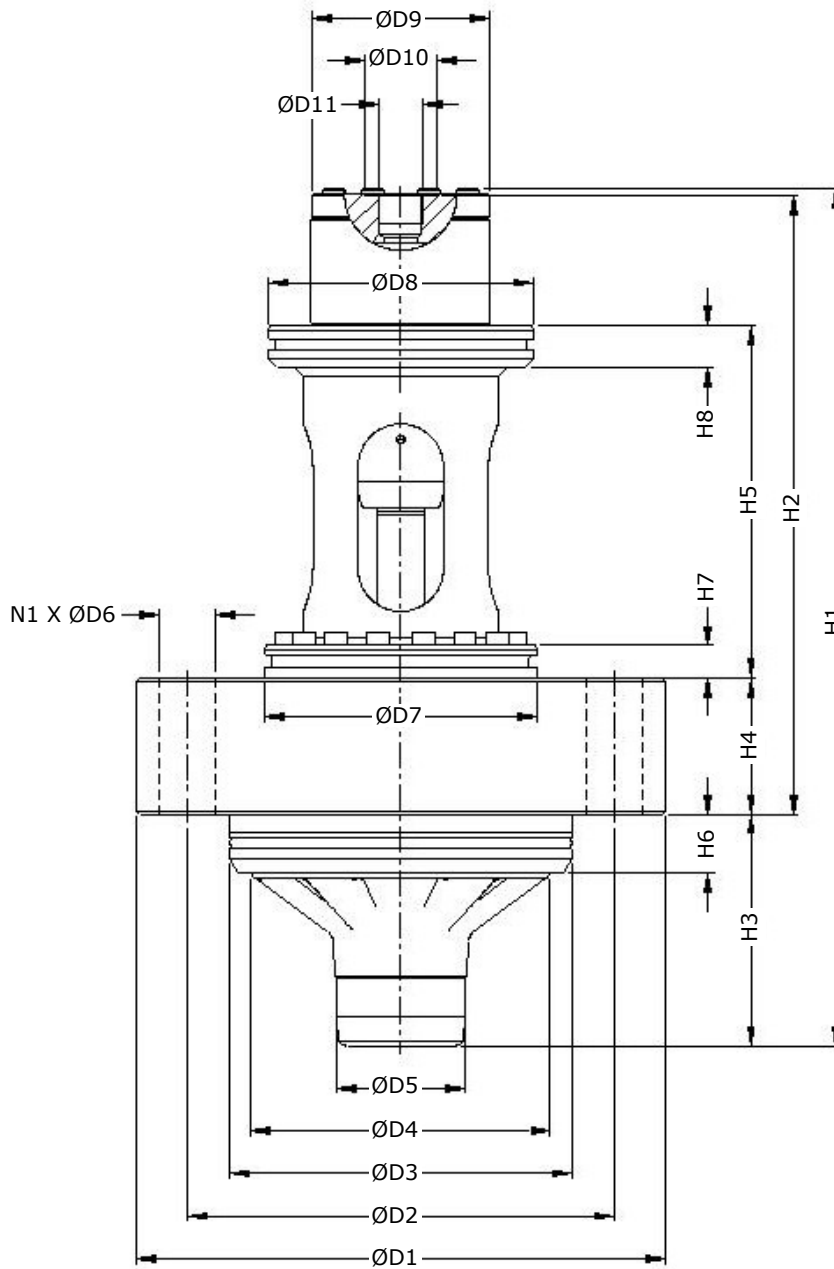

Dimensions in mm

Size	ØD1	ØD2	ØD3	ØD4	ØD5	ØD6	ØD7	ØD8	ØD9	ØD10
100	310	250	200	175	75	33	159	156	104	42
125	380	310	250	220	100	40	200	195	130	42
150	420	350	290	265	105	40	235	230	145	47
200	530	445	380	350	130	46	315	310	188	58

Size	ØD11	H1	H2	H3	H4	H5	H6	H7	H8	N1
100	G 3/4	503	363	136	80	207	35	19	25	12
125	G 3/4	588	422	160	90	248	35	21	26	12
150	G 1	680	494	180	100	298	35	23	27	15
200	G 1.1/4	896	644	240	120	379	55	31	40	18

Installation Dimensions: Mounting Style A—Flanged A Port

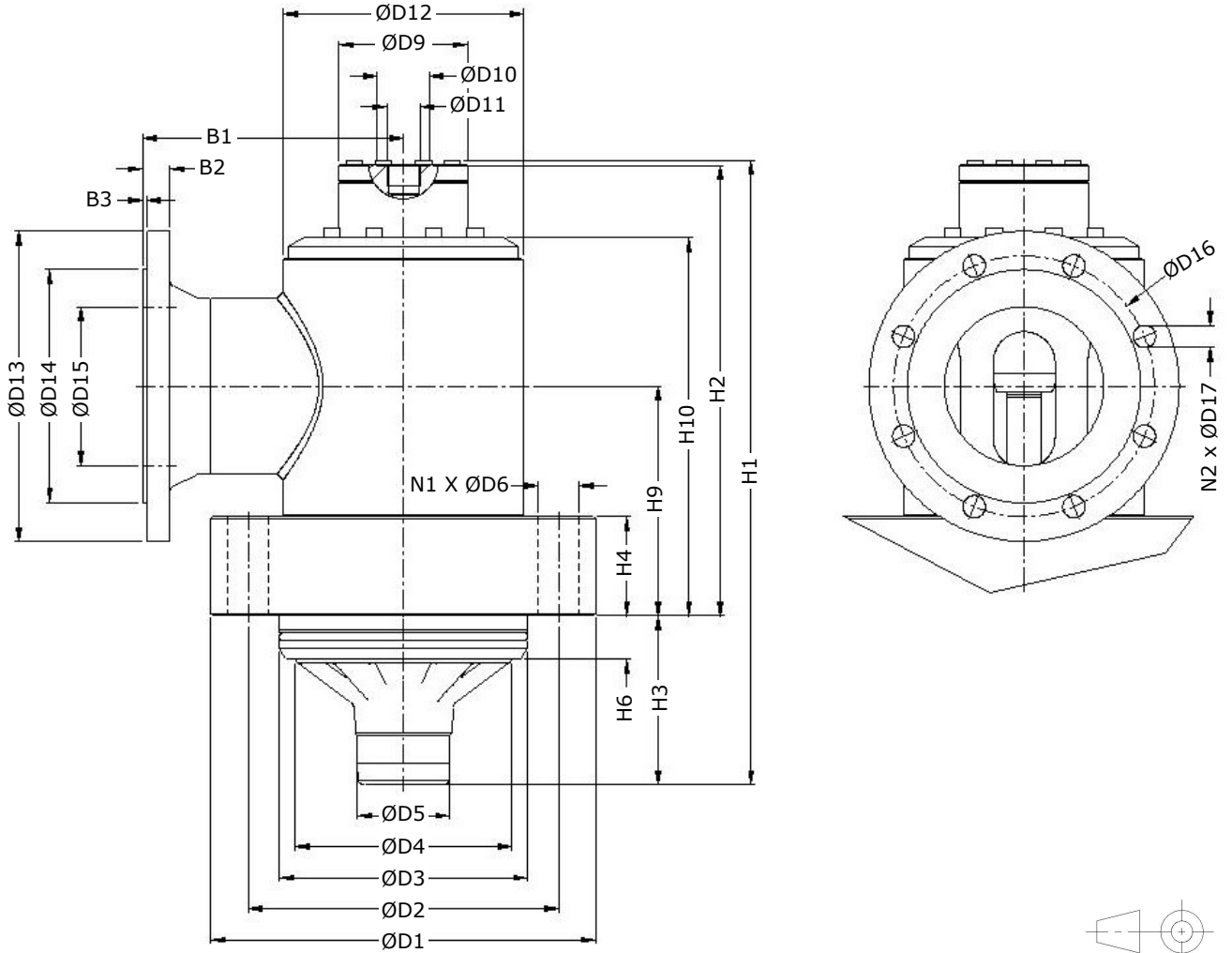

Dimensions in mm

Size	B1	B2	B3	ØD1	ØD2	ØD3	ØD4	ØD5	ØD6
100	210	22	3	310	250	200	175	75	33
125	250	22	3	380	310	250	220	100	40
150	275	24	3	420	350	290	265	105	40
200	330	26	3	530	445	380	350	130	46

Size	ØD9	ØD10	ØD11	ØD12	ØD13	ØD14	ØD15	ØD16	ØD17
100	104	42	G 3/4	193.7	250	188	128.1	210	18
125	130	42	G 3/4	244.5	285	212	154.1	240	22
150	145	47	G 1	273.0	340	268	202.7	295	22
200	188	58	G 1.1/4	355.6	405	320	254.4	355	26

Size	H1	H2	H3	H4	H6	H9	H10	N1	N2
100	503	363	136	80	35	185	305	12	8
125	588	422	160	90	35	220	358	12	8
150	680	494	180	100	35	255	420	15	12
200	896	644	240	120	55	320	535	18	12

Mounting Cavity

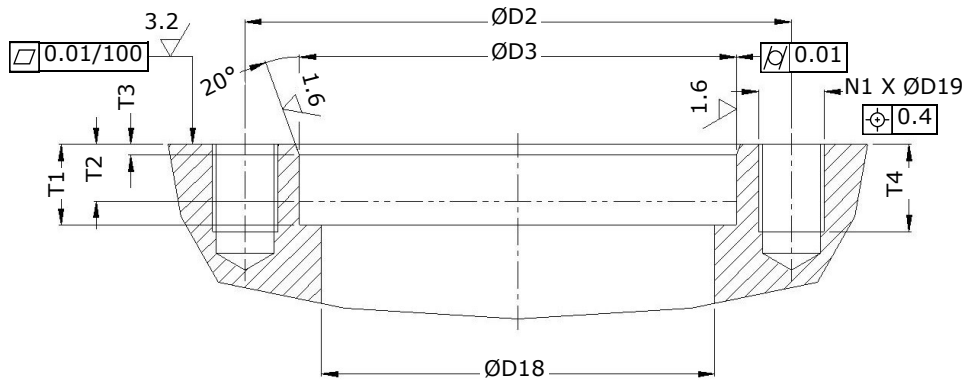

Size	ØD2	ØD3 (H7)	ØD18	ØD19	N1	T1	T2	T3	T4
100	250	200	180	M30	12	37	26	5	40
125	310	250	230	M36	12	37	26	5	60
150	350	290	270	M36	15	37	26	5	50
200	445	380	355	M42	18	57	42	8	60

Installation Notes: Avoiding Suction Vortex

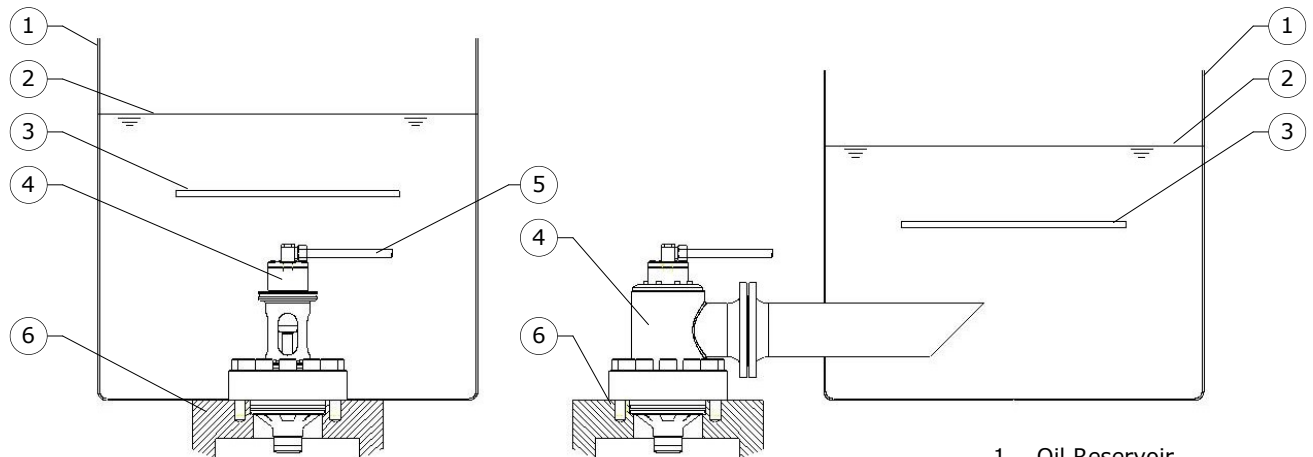

Install Baffle plates (3) at appropriate positions to avoid depressed suction vortex created during prefilling. Baffle plates are highly recommended for small reservoirs or low oil levels for both in-tank and flange mounting assemblies.

1. Oil Reservoir
2. Oil level
3. Baffle Plate
4. Prefill Valve
5. Pilot Connection
6. Cylinder

Installation Notes: Rotating Suction housing

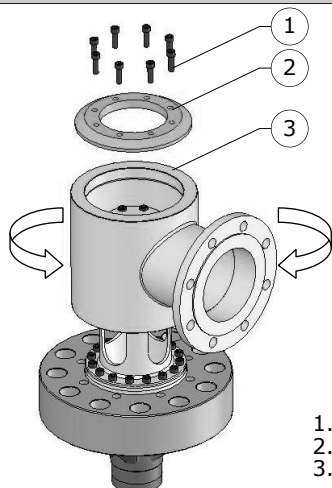

Suction housing and hence the flanged port A of the valve can be rotated around vertical axis through 360°. To rotate the suction housing

1. Loosen the clamp screws (1) and clamp (2) of the valve.
2. Rotate Suction housing (3) to desired position
3. Retighten the clamping screws

Note: Suction housing needs to be rotated around vertical axis to facilitate access to flange fixing bolts and for proper flange orientation.

1. Clamp Screws
2. Clamp
3. Suction Housing

Maximum flow for Different Application

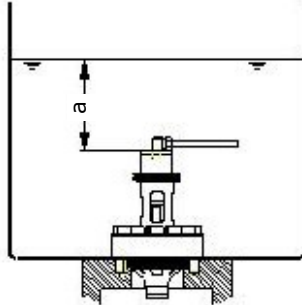

Application A

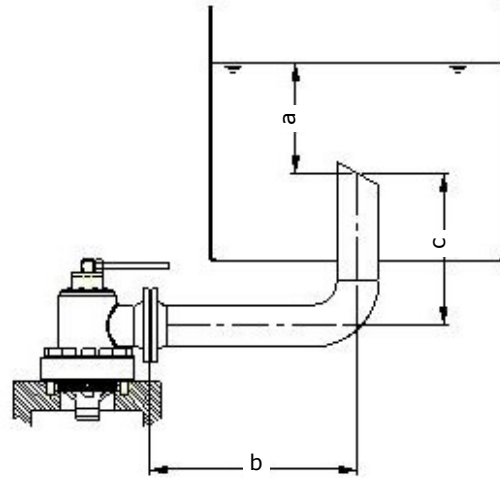

Application B

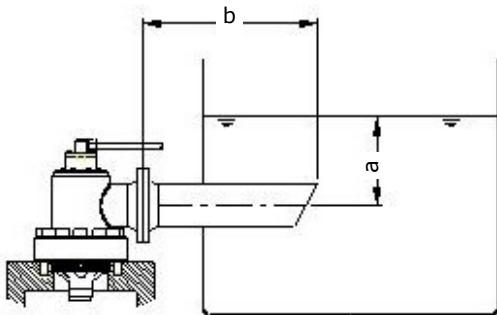

Application C

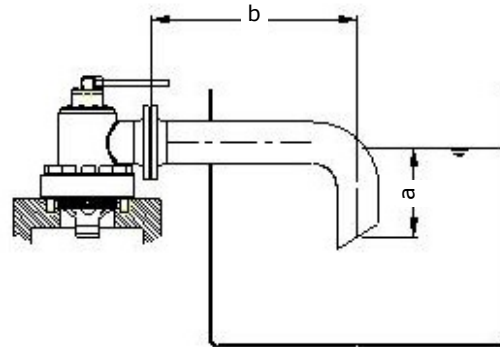

Application D

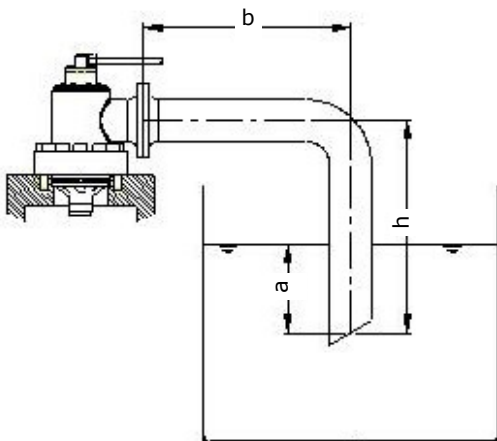

Application E

$a > 300$ when cylinder is extended
 $b < 1000$
 $c < 500$
 $300 < h < 500$

Maximum Flow (l/min)					
Size	Velocity	100	125	150	200
Application A	4.5	2120	3310	4770	8480
Application B	4.5	2120	3310	4770	8480
Application C	3.3	1560	2430	3500	6220
Application D	3.0	1410	2210	3180	5650
Application E	1.2	570	880	1270	2260